

2 Manufactured Homes

2.1 Manufactured Home Characteristics

Manufactured homes are one of several types of homes constructed entirely or partially in an off-site factory, transported over roadways, and then placed or assembled on a site-built foundation. After the home is in position, utilities (e.g., water, sewer, electric) are connected, ancillary components (e.g., siding, skirting) are installed, and the home is ready for habitation. Factory built homes include manufactured homes, modular homes, panelized homes, and pre-cut homes.

Modular, panelized, and pre-cut homes must comply with the same State and local building codes as “site stick built” codes. Manufactured homes must meet HUD regulations.

HUD regulations for manufactured homes are contained in 24 CFR 3280, *Manufactured Home Construction and Safety Standards* (MHCSS), and 24 CFR 3285, *Model Manufactured Home Installation Standards* (collectively referred to as the HUD codes). HUD regulations define manufactured housing as:

“..a structure, transportable in one or more sections, which in the traveling mode is 8 body feet or more in width or 40 body feet in length or which when erected on-site is 320 or more square feet, and which is built on a permanent chassis and designed to be used as a dwelling with or without a permanent foundation when connected to the required utilities” (24 CFR 3280.2 and 24 CFR 3285.5)

2.1.1 Chassis Support System

Manufactured homes are constructed on a chassis consisting of main steel beams and cross members; fitted axles, leaf springs, and wheels making up the running gear; and a steel hitch assembly. After the home is sited, the chassis frame distributes the manufactured home loads to the foundation system. The hitch assembly is generally removed for appearance purposes.

There are two general chassis designs. The traditional chassis system consists of two longitudinal steel beams (between 10 and 12 inches deep); steel cross members that span between the beams; and steel “outriggers” extend beyond the beams to support exterior walls of the home (Figure 2-1). Manufactured homes designed to be placed on perimeter foundation walls often are manufactured with shorter outriggers to provide clearance for the site-built foundation walls.

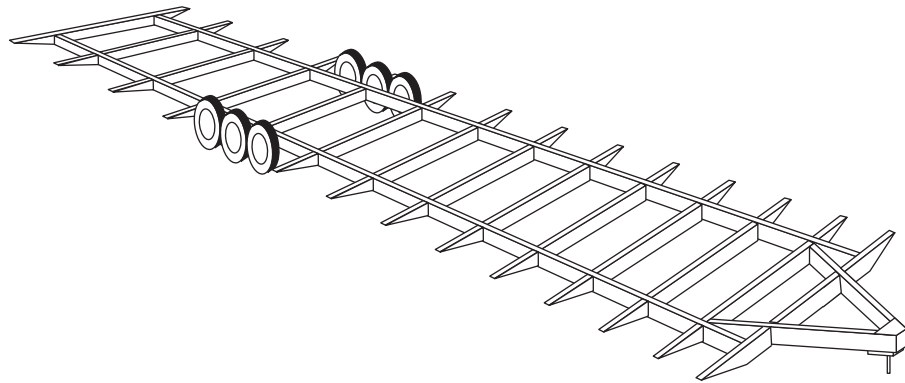

Figure 2-1. Traditional chassis system.

2.1.2 Integrated Support System

An alternative configuration relocates the steel main beams to the perimeter of the home, eliminating the cantilever “outriggers” (Figure 2-2).

Figure 2-2. Integrated floor system consisting of steel-reinforced perimeter framing.

Source: *Manufactured Home Producer's Guide to the Site-Built Market*, HUD.

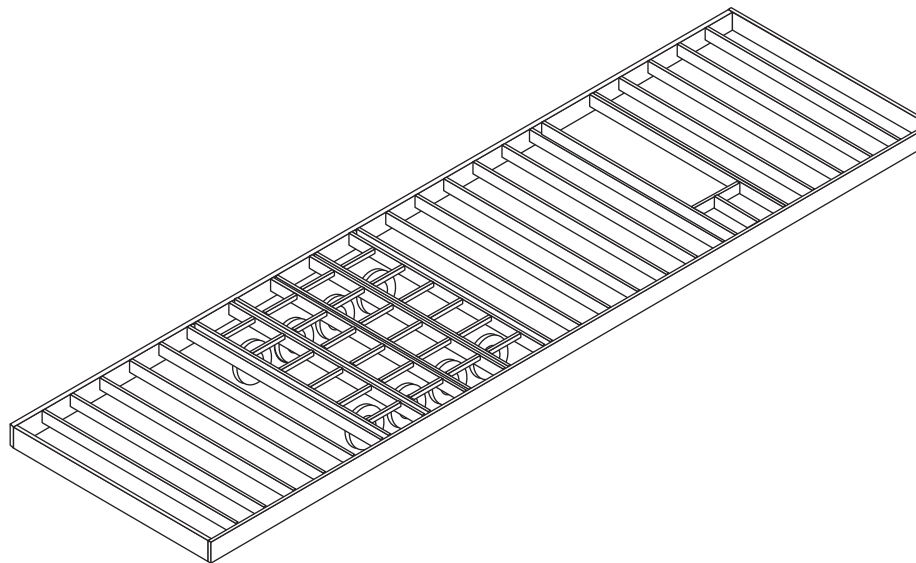

2.1.3 Envelope Construction

The manufactured home envelope must be designed to meet MHCSS (24 CFR 3280) strength and rigidity requirements. The floor decking material, attached to the floor joists, is usually wood composite panels or plywood. Floor joists spanning between steel cross beams generally are spaced at 16-inch centers. Exterior wall frames generally are constructed with wood studs, and the exterior of the home is generally covered with vinyl, aluminum, or wood siding. Common wood stud dimensions used in HUD Code housing are typically 2 inches wide by 3 inches deep, or 2 inches wide by 4 inches deep based on the design vertical and lateral loads. Some designs for manufactured homes located in HUD Wind Zone III require the use of studs 2 inches wide by 6 inches deep.

Interior structural walls must have the structural capacity adequate for their intended use, with a minimum capacity to resist a horizontal load of 5 pounds per square foot (24 CFR 3280.305(f)(2)). Interior wall frames typically use 2-inch by 3-inch wood studs. Interior non-structural walls can use 1-inch by 2-inch studs for framing.

The roof and ceiling system is typically constructed with prefabricated scissor trusses or other peaked trusses, sheathed with composite roof panels, underlayment, and shingles. Roof trusses typically are spaced at 24-inch centers.

Other construction features of manufactured homes include insulation, vapor barriers, gypsum wall and ceiling board, exterior roof and wall sheathing, doors and windows, and other finishing materials similarly found in site-built and modular homes. Figure 2-3 shows the main construction features of a typical manufactured home, including the envelope construction elements.

2.1.4 Double Section

A double-section manufactured home is constructed from two single floor sections and is, therefore, generally twice as wide as the normal 12- to 16-foot wide single-section unit. The design and construction of the chassis/floor system is comparable to that of the single-section unit. The double section is transported as two separate floor sections (Figure 2-4). The floor sections are then attached at the home's site. The area where the two floor sections come together is called the marriage line. Marriage beams, beam joists, and walls are properly aligned and connected at the site. The roof, walls, and floor along the marriage line must be properly aligned, sealed, and supported.

2.2 Types of Foundation Systems

Typical types of foundation systems used to support a manufactured home located in SFHAs include the following:

- Piers and ground anchors.
- Perimeter wall foundations.
- Proprietary foundation systems that transmit loads from the manufactured home to the ground using patented components or assemblies.

The HUD Codes (24 CFR 3285 Subparts D – Foundations and E – Anchorage Against Winds) provide design standards for pier foundations and anchor systems, including ground anchors. Alternative foundations must be manufactured and installed in accordance with their listings by a nationally recognized testing laboratory, based on a nationally recognized testing protocol, or be designed or tested by a registered professional engineer or architect in accordance with accepted engineering practice, and must not take the home out of compliance with the MHCSS (24 CFR 3285.301).

Figure 2-3. Main construction features of a typical manufactured home.

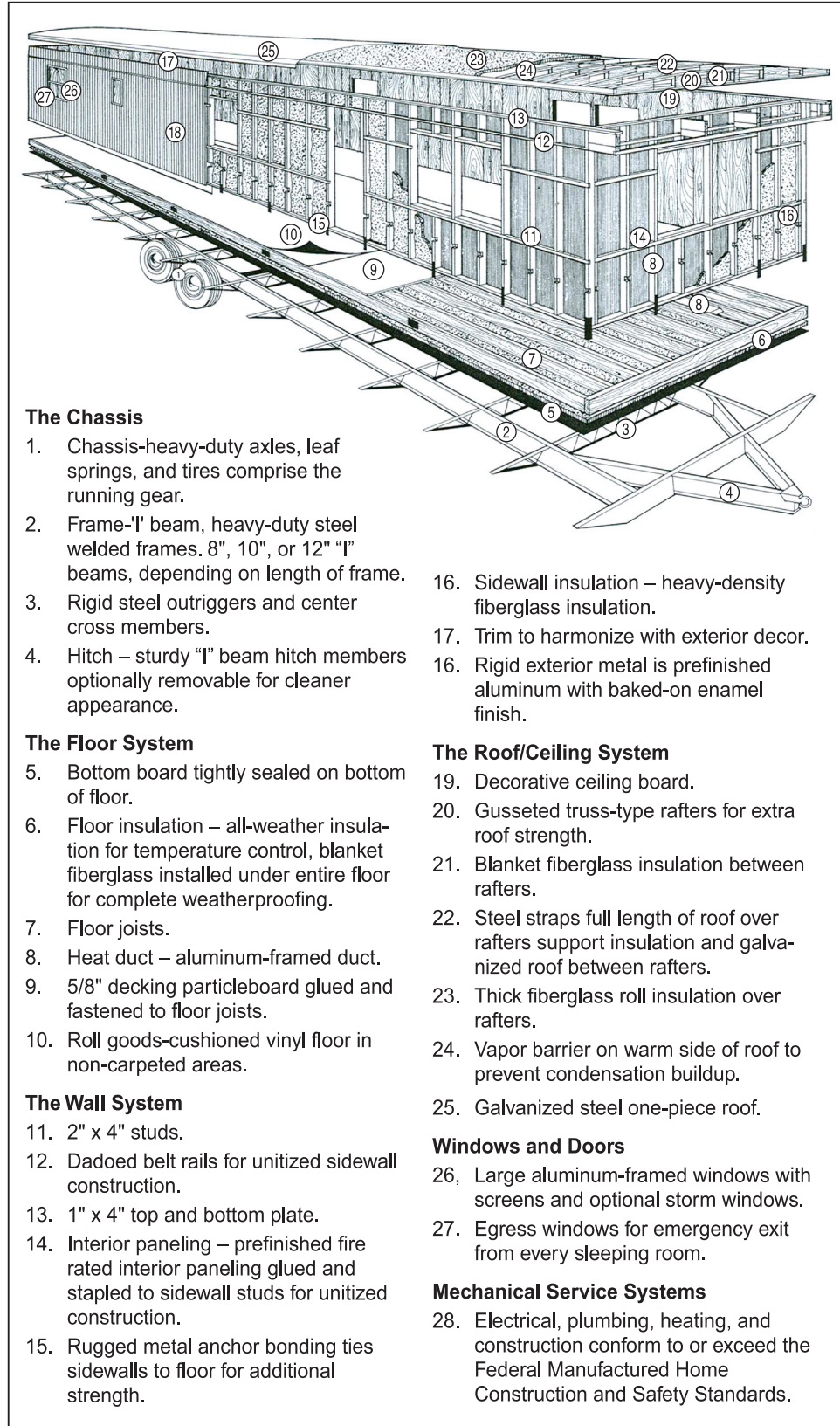

The Chassis

1. Chassis-heavy-duty axles, leaf springs, and tires comprise the running gear.
2. Frame-I beam, heavy-duty steel welded frames. 8", 10", or 12" "I" beams, depending on length of frame.
3. Rigid steel outriggers and center cross members.
4. Hitch – sturdy "I" beam hitch members optionally removable for cleaner appearance.

The Floor System

5. Bottom board tightly sealed on bottom of floor.
6. Floor insulation – all-weather insulation for temperature control, blanket fiberglass installed under entire floor for complete weatherproofing.
7. Floor joists.
8. Heat duct – aluminum-framed duct.
9. 5/8" decking particleboard glued and fastened to floor joists.
10. Roll goods-cushioned vinyl floor in non-carpeted areas.

The Wall System

11. 2" x 4" studs.
12. Dadoed belt rails for unitized sidewall construction.
13. 1" x 4" top and bottom plate.
14. Interior paneling – prefinished fire rated interior paneling glued and stapled to sidewall studs for unitized construction.
15. Rugged metal anchor bonding ties sidewalls to floor for additional strength.

16. Sidewall insulation – heavy-density fiberglass insulation.
17. Trim to harmonize with exterior decor.
16. Rigid exterior metal is prefinished aluminum with baked-on enamel finish.

The Roof/Ceiling System

19. Decorative ceiling board.
20. Gusseted truss-type rafters for extra roof strength.
21. Blanket fiberglass insulation between rafters.
22. Steel straps full length of roof over rafters support insulation and galvanized roof between rafters.
23. Thick fiberglass roll insulation over rafters.
24. Vapor barrier on warm side of roof to prevent condensation buildup.
25. Galvanized steel one-piece roof.

Windows and Doors

26. Large aluminum-framed windows with screens and optional storm windows.
27. Egress windows for emergency exit from every sleeping room.

Mechanical Service Systems

28. Electrical, plumbing, heating, and construction conform to or exceed the Federal Manufactured Home Construction and Safety Standards.



Figure 2-4. One section of a double-section manufactured home being transported.

Source: Manufactured Housing Institute.

Additional technical information on foundation systems for installation of manufactured homes is provided in Chapter 8 of this guide.

2.2.1 Typical Foundation Systems

2.2.1.1 Typical Installation

A manufactured home is typically placed on a site that has been stabilized and improved to provide adequate support for the home and anchoring system. Site and area improvements techniques vary widely across the country. Typical improvement techniques include simple ground stabilization (ground compaction), application of gravel, and/or construction of a concrete runner or slab.

Typical manufactured home foundations consist of a system of piers and ground anchors (refer to Section 2.2.1.2). Piers are typically placed beneath the two steel beams at a spacing of 8 to 10 feet along the length of the manufactured home. Frame ties are connected to the steel chassis or perimeter beams, and run to ground anchors (Figure 2-5) that are used with tie-downs and straps to secure a manufactured home in place. The frame ties and anchors provide lateral support; the piers provide vertical support.

Although typical manufactured home foundations and installation methods often address wind events, many give little consideration to the forces associated with flooding and seismic events. They generally are not designed for flood effects such as hydrodynamic and hydrostatic forces, buoyancy, erosion, and scour. Potential failure modes observed in a typical installation include:

- **Buoyancy**, particularly during rapidly rising floodwaters
- **Lateral movement**, particularly when exposed to moving floodwaters that extend above the home's steel beams

- **Pier collapse**, particularly when homes are exposed to wind and moving floodwaters simultaneously
- **Erosion and scour**, particularly when homes are exposed to high velocity floodwaters

2.2.1.2 Piers and Ground Anchors

Using both pier foundations and anchor assemblies together is the most common type of foundation system (Figure 2-6). Piers support the gravity loads of the home, and the anchors resist uplift and lateral loads. Piers are installed under the main beams of the home sections, under the marriage line of multi-section homes, and at locations designated by the home manufacturer. Common types of piers include several configurations of steel jack stands and stacked, reinforced or unreinforced hollow-core concrete masonry blocks of various configurations. Ground anchors, a specific anchoring assembly, typically consisting of auger-type (screw-in) ground anchors, are the most commonly used. The anchor is attached to the home’s steel beams by steel straps. Chapter 7 discusses ground anchors in more depth.

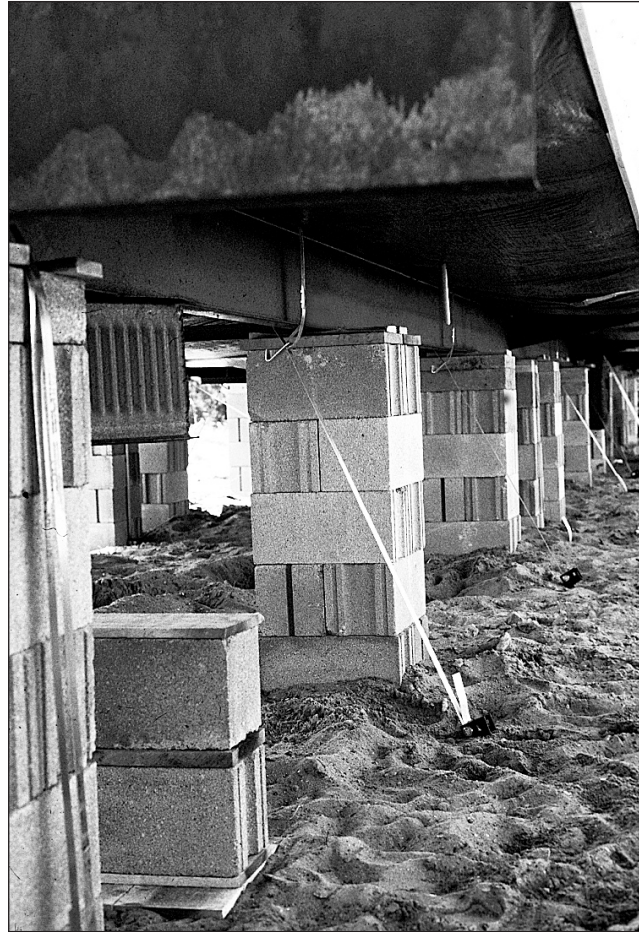
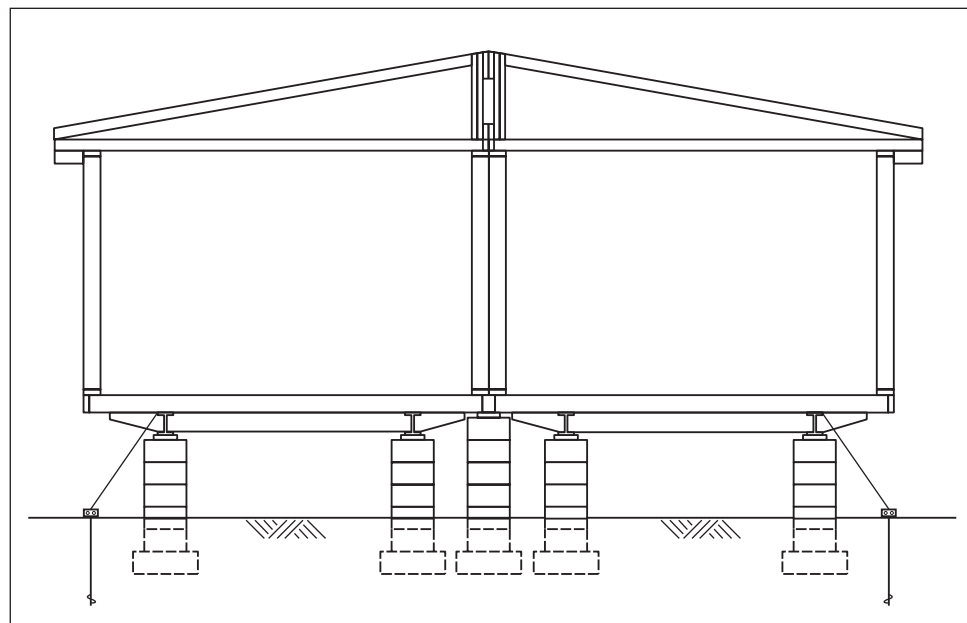

Figure 2-5. Typical installation of a manufactured home on masonry block piers with tie-down straps.

Figure 2-6. Typical installation of a double-section manufactured home on a pier and ground anchor foundation system.



The advantages of this foundation system are that it adapts easily to the site conditions, does not require much dimensional precision, is installed very quickly, and is economical to install.

2.2.1.3 Perimeter Wall Foundations

When perimeter foundations are used with a manufactured home constructed with chassis beams, the chassis beams provide support for gravity loads, and the perimeter walls resist uplift and lateral loads. When used with a manufactured home constructed with an integral floor framing system, the perimeter walls resist uplift, lateral, and gravity loads (Figure 2-7). With chassis systems, interior piers support the chassis, points along the marriage wall, and other areas of concentrated loads.

Perimeter walls can be constructed with typical building materials (e.g., cast-in-place concrete, masonry, or preservative-treated wood); footings are generally cast-in-place concrete. Attaching the floor joists to the foundation wall provides resistance to horizontal and uplift forces.

Some considerations in using this system include the following:

- The system must be precisely measured and constructed before the home is delivered to the site.
- Typically, a crane or roller system will be needed to place the home onto the foundation.

The cost and construction time of this system is greater than the pier and ground anchor foundation system.

2.2.2 Proprietary Systems

A proprietary foundation is a patented system manufactured and sold only by the owner of the patent or licensee. If a proprietary system is selected for a manufactured home, it must be capable of resisting all design loads of the MHCSS, and those imposed by any site-specific natural hazards. (See the checklist on the next page for more information.)

The Systems Building Research Alliance (SBRA, formerly the Manufactured Housing Research Alliance [MHRA]) has evaluated proprietary and non-proprietary foundation systems for manufactured homes. Their publication, *Guide to Foundation and Support Systems for Manufactured Homes*, provides guidance for deciding among alternative foundation designs that are appropriate for a given site and budget. The SBRA is also continuing to conduct research foundation systems developed for use in SFHAs.

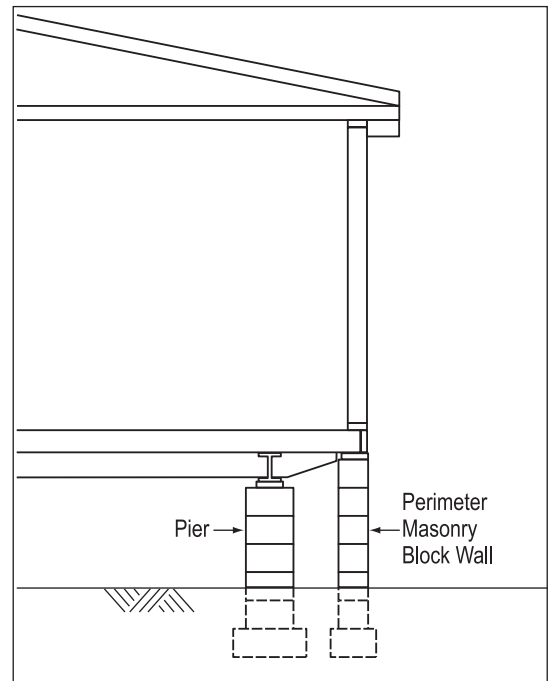

Figure 2-7. Perimeter wall foundation under a manufactured home.

Proprietary Foundation System Checklist

- **Identify type of natural hazards for the manufactured home site.** Follow the steps in Chapter 9 of this guide.
- **Identify natural hazards design loads for the manufactured home.** Follow the steps in Chapter 9.
- **Check design loads on engineering drawings or specifications.** Design loads must be greater than or equal to the loads identified in Step 2 of Chapter 9.
- **The drawing must have a professional engineer's or architect's seal,** ensuring the system was designed by a professional.

2.3 Utilities and Mechanical Equipment

2.3.1 Utilities Placement

Care needs to be taken in the placement of utilities (such as water, sewer, and gas services) and mechanical systems. Connecting the manufactured home to these utility and mechanical systems requires them to extend from the grade beneath the home up through the floor. Their location makes them susceptible to being inundated by floodwaters and damaged by floating debris. Therefore, separating these systems to protect them is important. To minimize damage to utility lines, they should be placed in waterproof risers located adjacent to the elevated foundation member on the downstream side of the expected (or anticipated) flood flow.

State and local codes and regulations must also be followed for utility services installations and connections. These provisions may require the waterproofing of all connections, the use of certain specific waterproof materials, and backflow preventers on water and sewage service. Underground telephone and electric service should also be enclosed in a riser and protected from damage in a similar manner. If electrical and telephone service is supplied from overhead lines, the service connection to the manufactured home must be located above anticipated flooding.

Special care must be taken in running underground utilities to homes. Differential movement between the home and utility can cause failure of the home to utility connection. Failures can cause electrical shock hazard or leakage of gas, water, or raw sewage. Similar problems can occur when utilities run through uncompacted backfill around a basement excavation or when utilities are subjected to seismic loads. Installing a flexible connection in the line is one way to reduce potential line breakage.

It is possible that a home with utility services could be displaced in a design wind or a seismic event. By design, ground anchors that are used to hold down many homes will displace on the order of 2 to 3 inches. Seismic forces can cause even higher displacements to utility connections than a design wind event (Figure 2-8). Therefore, some flexibility must be provided in the

utility lines to accommodate for any potential movements. Utility attachments to the manufactured home should be capable of accommodating the anticipated seismic and wind displacement of the support and anchorage system.

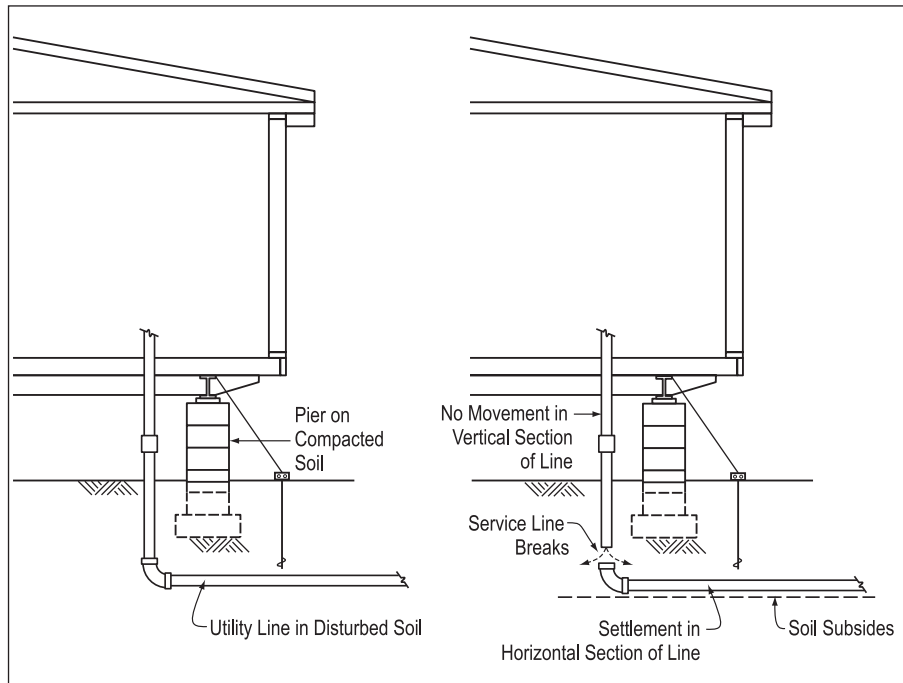

Figure 2-8. Utility line damage in unstable soils.

Propane and fuel oil tanks used to supply energy for heating or other services should be anchored against flotation or elevated above the anticipated flood level. Tank foundations should be separated from the home's foundation system. To minimize the potential for debris impact and damage, tanks and their supporting foundations should be located on the downstream side of homes. Bollards can be used to deflect floodborne debris and reduce the potential of impact damage. Additional information on utility systems for manufactured homes in the floodplain is provided in Section 3.6.7.

For manufactured homes located in seismic areas, site-installed water heaters should be provided with seismic bracing straps in accordance with the manufacturer's recommendations. Strapping a water heater to a wall to prevent it from falling over is an easy and cost-effective seismic mitigation measure. Other site-installed equipment weighing more than 100 pounds should be anchored to resist horizontal seismic forces.

2.3.2 Mechanical Access

Components of heating and air-conditioning systems installed within manufactured homes are generally located above the floor. When the home is elevated to the BFE, interior components are protected. However, components located below the floor remain vulnerable to flood damage. In particular, exterior heating and air conditioning compressors, and crossover ducts are common components that are damaged by floodwaters.

Compressor units can be elevated by placing them on platforms at the BFE; however, crossover ducts require the entire home to be elevated 1 to 2 feet above the BFE to prevent them from being damaged during the design flood.

2.4 Attachments – Carports, Decks, Porches, and Awnings

Carports, decks, porches, and awnings are often attached after the manufactured home has been installed. The HUD installation standard (24 CFR 3285.3) requires that attachments must not impose loads to the manufactured home or its foundations unless the attachments are included in the manufacturer's approved designs and installation instructions, or the attachments are designed by a registered engineer or architect consistent with the manufacturer's design. Similarly, the International Residential Code® (IRC®) requires that accessory buildings (e.g., carports, decks, porches, and awnings) shall not be structurally supported by or attached to a manufactured home unless engineering calculations are submitted to substantiate any proposed construction (IRC 2006 AE 504.1).

Carports, decks, porches, and awnings should only be built as stand-alone units. Additionally, if a stand-alone deck or porch is going to be added, design criteria for vertical foundation members on the addition should be equivalent to those for the foundation system of the main structure to prevent damage to the main structure from adjacent structures.

During the Hurricane Charley post-event assessment (2004), engineers noted the failure of these attached structures (in many places, occurring where wind speeds were below the design wind speed for the area), resulting in extensive damage to roof coverings, siding, and windows of the manufactured units, and generating significant amounts of debris.